

Types of Conveyor and Sortation Systems

MODULE 2

CSS: Who We Are

The **Conveyor and Sortation Systems (CSS) Industry Group** members are the industry's leading providers of conveyors, sortation systems, and their components. They design, fabricate, and install conveyor and sortation systems worldwide and in virtually every major manufacturing and distribution sector. CSS prepares and distributes educational and promotional materials regarding the proper application and benefits of conveyor and sortation system solutions. CSS also publishes and promotes materials on the training, inspection, safety and maintenance of conveyors and sortation systems.

The **Vertical Reciprocating Conveyor (VRC) Subcommittee of CSS** is comprised of the industry's leading suppliers of material lifts. They design, manufacture, and install VRCs worldwide for use in a wide variety of industrial, commercial, and institutional operating environments.

MEMBERS

To meet the current members of the Conveyor and Sortation Systems Group, [click here](#).

CSS MISSION & VISION STATEMENT

Mission:

To promote the market growth and effective use of conveyor and sortation systems in manufacturing, warehousing, distribution and other key markets.

Vision:

To be the recognized independent authority for end users and suppliers on market trends, technology developments, and applications through:

- Education
On key features, advantages, and benefits
- Key Issues
Issues affecting our marketplace through user outreach
- Development
Development and distribution of educational materials
- Collaboration
Of manufacturers & technology providers
- Promotion
Promotion of career opportunities within the CSS industry

VALUE STATEMENT

To CSS Customers

Recognized since 1971 as Leaders in the design, manufacturing, and supply of Conveyor and Sortation Systems Equipment, Components, and Technology.

Invested in the conveyor industry in unique ways over time, including giving back through college scholarships, and end user and manufacturer education.

Can provide end users with access to a wide range of perspectives and solutions, and as a collective of manufacturers, are genuinely invested in customer success.

[LEARN MORE ABOUT CSS MEMBERS >>](#)

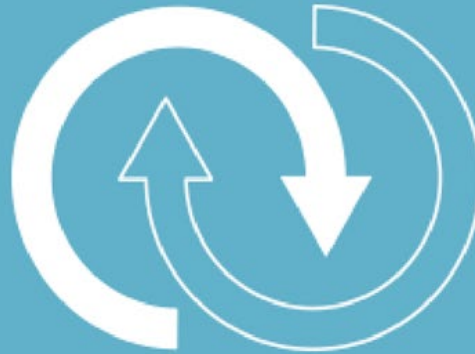

To CSS Members

Unique networking opportunities.

Provide opportunities for industry education, leadership, and increased market presence.

Lend your company the collective credibility of its industry leading members that has been established over its nearly 50 years as an organization.

Provide exposure to end users.

Access to data on industry trends and other market intelligence data.

[JOIN CSS TODAY >>](#)

1 Market Intelligence

- Market forecasts and economic indicator monitoring
- Industry commodity forecasts
- Trend monitoring

2 Networking & Access to Industry Peers

- Leadership development
- Networking with other subject matter experts throughout the industry
- Peer to peer interaction which promotes collaboration and industry betterment

3 CSS Members are recognized as Market Leaders

- Offer collaborative responses to regulatory changes
- Are invested in the promotion, safety, and success of the conveyor and sortation systems industry
- Have been recognized as industry leaders since 1971
- Are Subject Matter Experts

4 Increased Exposure to End-Users & Increased Business Opportunities

- Web-based case studies provide potential solutions and increase engagement with end-users
- Blogs for Industry Awareness and Promotion
- End-user Educational Publications

The **Conveyor and Sortation Systems (CSS) Industry Group** of MHI combines the knowledge and experience of thousands of installations. For more information and current members, visit mhi.org/css.

Conveyor Types

GRAVITY, POWERED, AND SPECIALIZED

Gravity Conveyors

The simplest kind, gravity conveyors feature an incline and use the force of gravity, or of a person, to push the load along the conveyor surface. The main types include:

- Chute Conveyor
- Gravity Roller Conveyor
- Gravity Wheel Conveyor



Chute Conveyor

The most basic style, chute conveyors feature a solid surface made of metal or plastic that is angled down in a straight or spiral configuration. The load slides along the surface.



Gravity Roller Conveyor

Supporting a load on a series of rollers with internal ball bearing rings mounted on axles at fixed intervals in a frame. They come in straight, curved, spur or merge configurations.



Gravity Wheel Conveyor

Ideal for light duty handling of loads with flat, smooth bottoms, gravity wheel conveyors support the load on a series of skate wheels mounted on a shaft in a frame. The conveyor sections can be fixed or a flexible, expandable accordion frame.

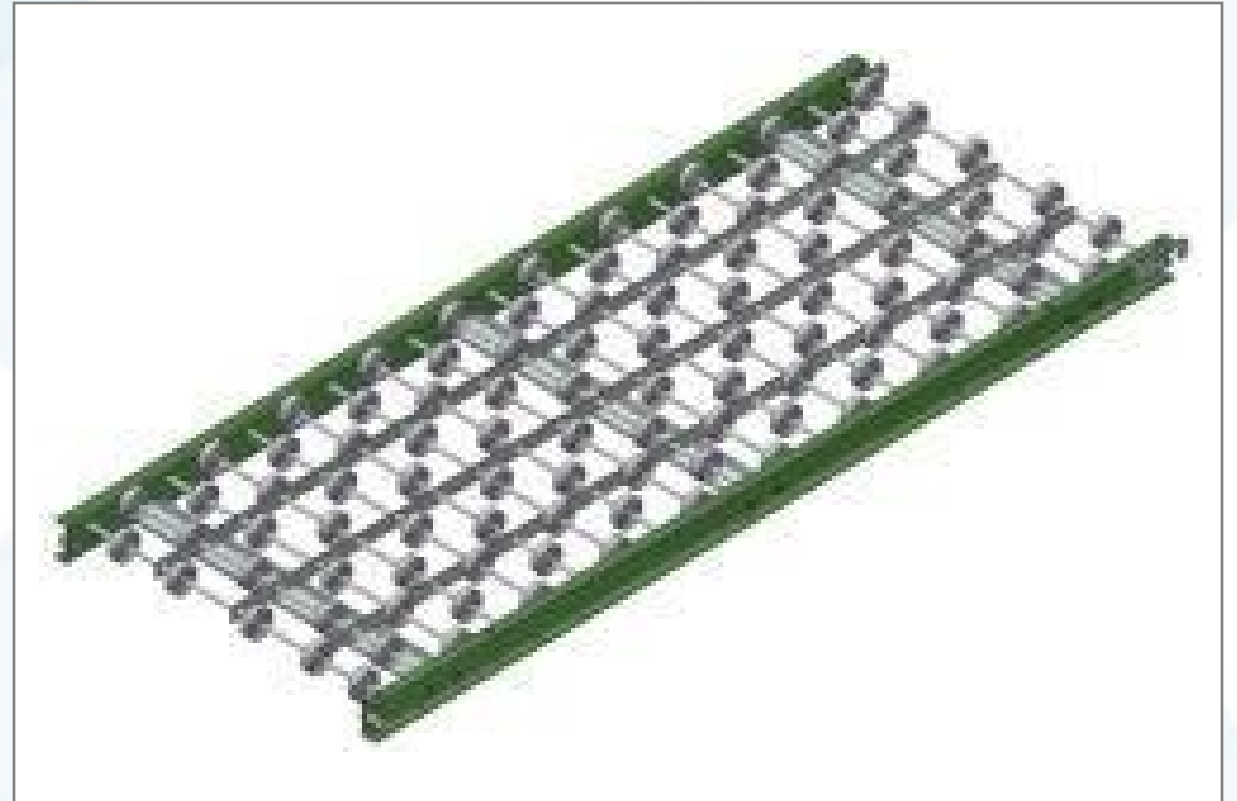

Powered Conveyors

Driven by either an electric or pneumatic power system, a powered conveyors' movement is driven by motors and drives. There are several types, including:

- Accumulation Conveyor
- Belt Conveyor
- Chain Conveyor
- Live Roller Conveyor
- Paternoster or Platform Conveyor (also known as a Vertical Lift Conveyor or Lifting Station)
- Slat Conveyor



Accumulation Conveyor

A conveyor that accumulates loads at a location. To avoid any abrupt collisions of (or damage to) the loads, a variety of methods are employed to slow their travel speeds. These include:

- Non-contact
- Minimum pressure
- Zero pressure

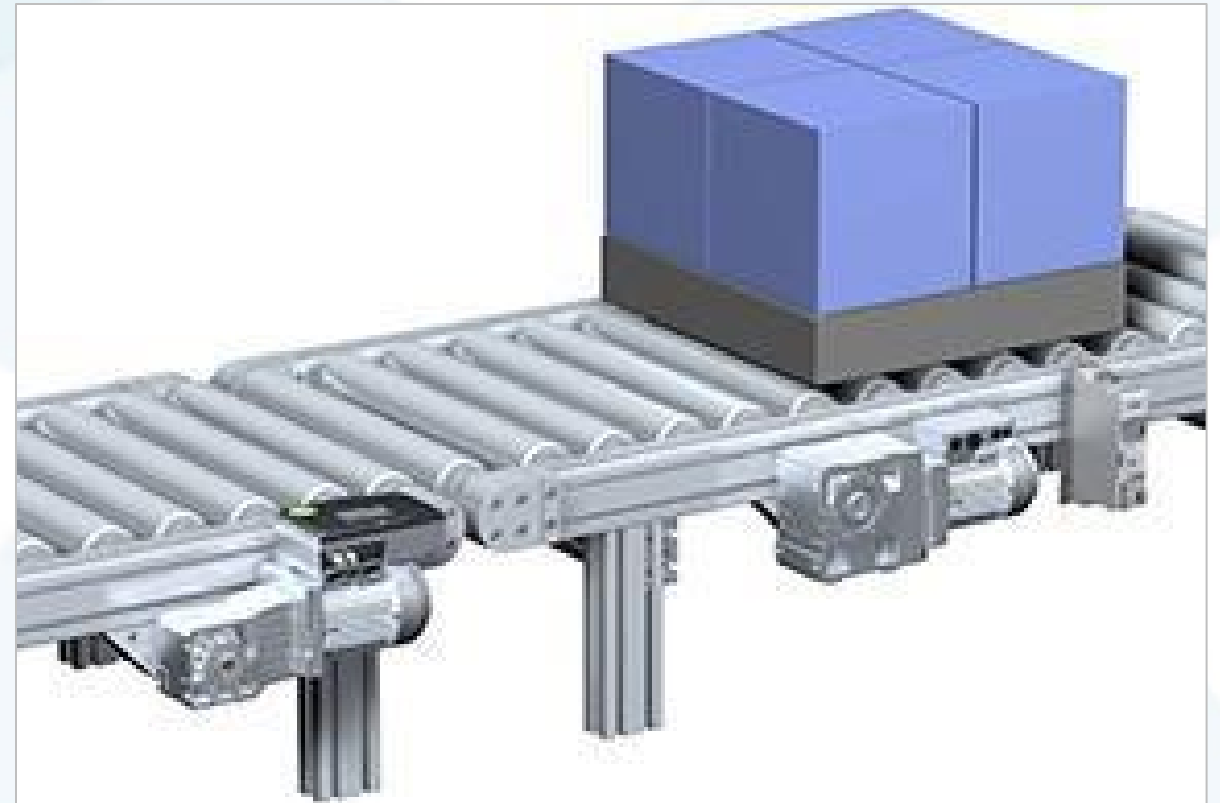

Belt Conveyor

A powered conveyor that transports loads on belts made of fabric, rubber, plastic, leather, or metal. Types include:

- Roller
- Slider
- Telescoping



Chain Conveyor

Transporters of heavy unit loads (such as pallets or containers), chain conveyors use a single or double chain that provides the driving force to pull the load forward.

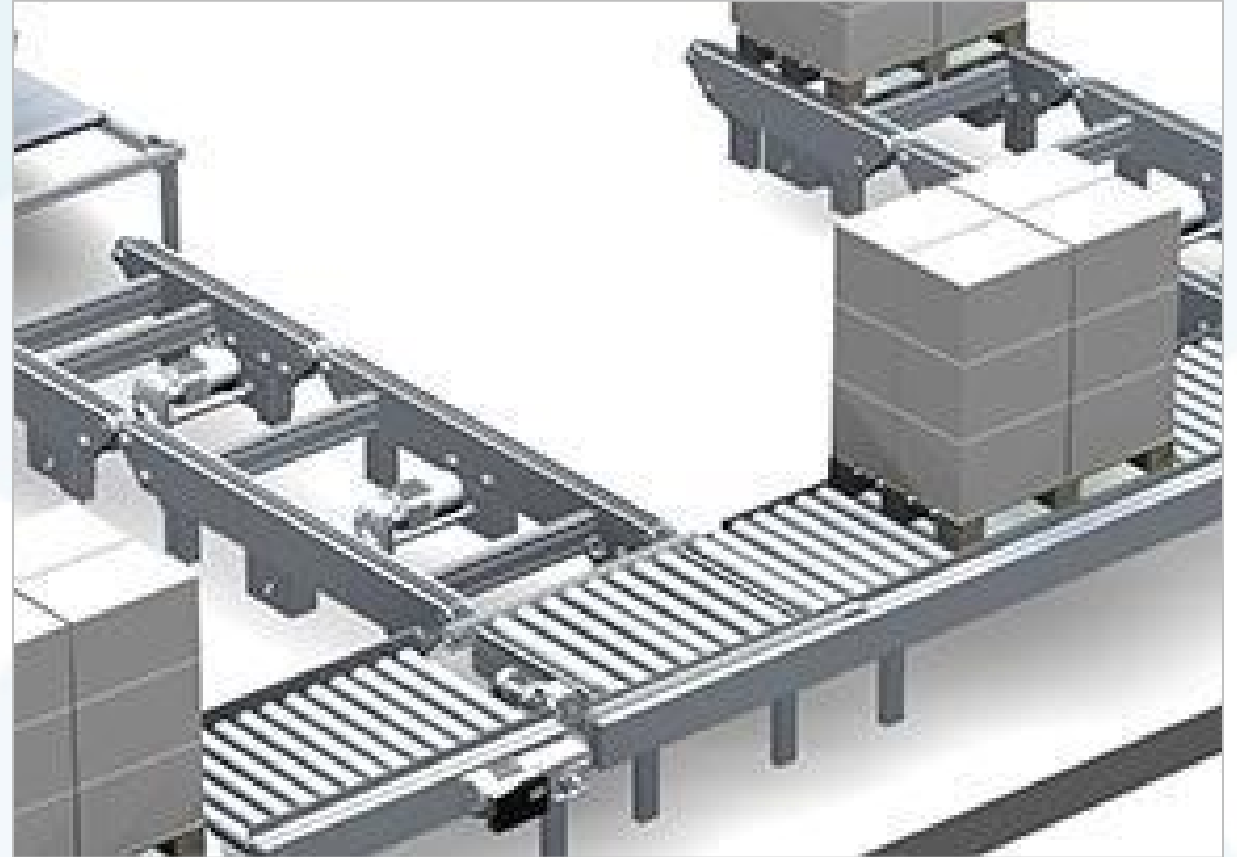

Live Roller Conveyor

This is the most common conveyor used in warehousing. Loads travel on rollers mounted in a frame and powered through various means. Types include:

- Belt Driven
- Line Shaft Driven

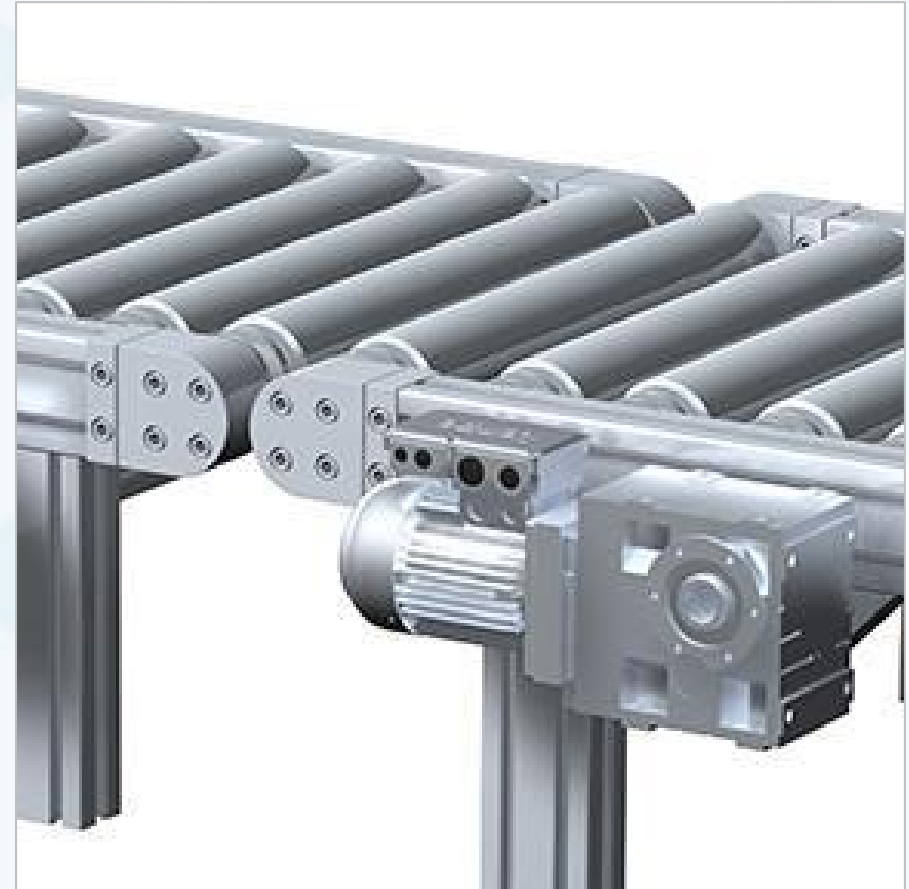

Paternoster or Platform Conveyor

ALSO KNOWN AS A VERTICAL LIFT CONVEYOR OR LIFTING STATION

A type of vertical conveyor that includes multiple, equally spaced, load-carrying units fixed to chains that move continuously in an endless loop. This permits automatic loading and unloading.

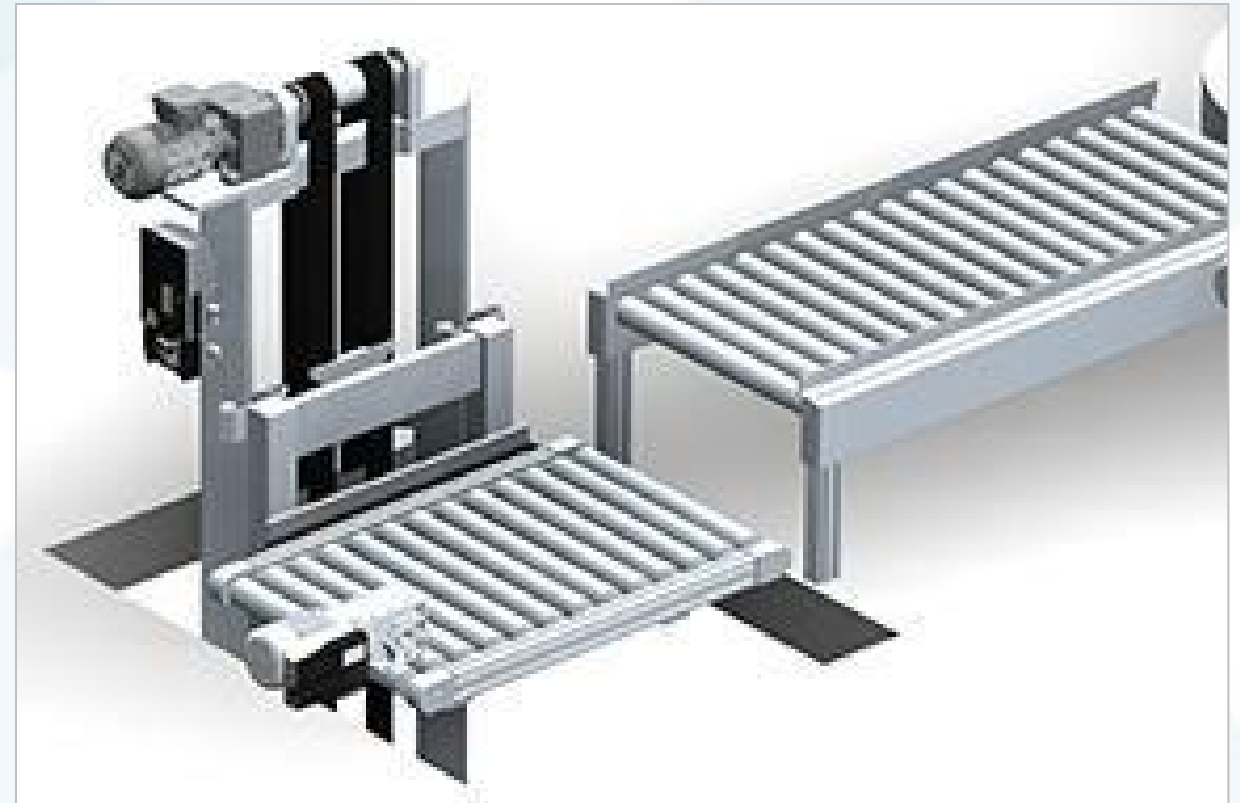

Slat Conveyor

Utilizes one or more endless chains that have non-overlapping, non-interlocking, spaced slats attached. Loads ride on the slats.



Specialized Conveyors

Utilized in a variety of applications—typically manufacturing and materials processing (as opposed to warehousing and distribution)—there are numerous types of specialized conveyors.

These include:

- Vertical Reciprocating Conveyor (VRC)
- Tow Conveyor



Vertical Reciprocating Conveyor (VRC)

For transferring a load from one level to another, VRCs feature a platform that moves up and down to carry materials or objects from one belt or roller conveyor to another. Lifting power is usually generated via mechanical or hydraulic means. There are three styles:

- **Two Post Cantilever Lift** – Carriage guided and supported by two masts on the same side for three-sided accessibility for C-, Z- or 90°-loading.
- **Two Post Straddle Lift** – Carriage guided by and suspended between two masts on opposite sides for C- and Z-loading.
- **Four Post Lift** – A type of straddle lift carriage with two sets of two masts on opposite sides for higher capacities and C-, Z- or 90°-loading.



Tow Conveyor

Tow conveyor utilizes a cable, or towline, embedded in the floor to pull wheeled carriers that sit beneath loads across a floor.



Sortation Equipment Types

Deflector

A stationary or moveable angled arm that deflects product flow across a belt or roller conveyor to the desired location.

Included are impact deflectors that utilize a swing out arm that avoids contact with the conveying surface but impacts the side of the load to produce a lateral change in direction.

Examples include powered (such as pneumatic, electric, or hydraulic) or manually positioned. The deflector face can also be either powered or friction faced.



Diverters

A diverter is mechanical device that sits above a conveying surface and uses electric, hydraulic, or pneumatic power to push, pull, or move a case, carton, or piece off the main conveyor line. The movement targets the side of the load.

There are five diverter types:

- Impact
- Line Shaft
- Push Driver
- Pneumatic Pusher
- Pneumatic Puller



Divorter Types



Impact Diverters – Mechanically actuated push plate that impacts the side of a load to move it.

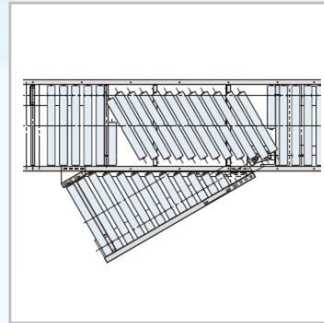

Line Shaft Diverter – Roller diverters used in a line shaft driven roller conveyor to redirect materials.



Push Driver – Computer-controlled arm pushes items at a right angle.

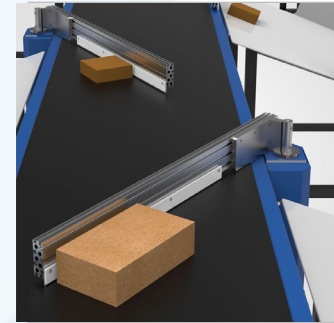

Pneumatic Pusher – Air-powered ram and cylinder that push materials off the main conveyor line.

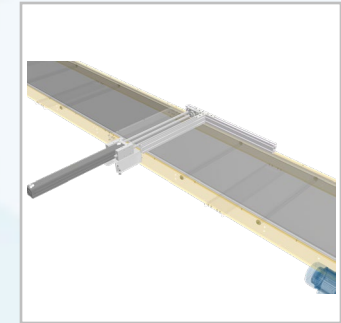

Pneumatic Puller – Air-powered device that travels beyond the object to be redirected and retracts, pulling it in the desired direction.

In-Line Diverters

Also called moving surface diverters or pop-up diverters, these mechanical devices are integrated into the main conveying surface and rise above that surface on command. This action changes the direction of a load's movement via direct contact with its underside.

There are five in-line diverter types:

- Pop-up Chain Sorter
- Pop-up Rollers or Roller Diverter
- Pop-up Skewed Wheel Sorter
- Rake Puller
- Powered Wheel Diverter



In-Line Diverter Types



Pop-up Chain Sorter – For perpendicular changes to conveying direction in load transfer of heavy, slow-moving pallet loads. Includes chain, O-ring, timing belt, and v-belt.

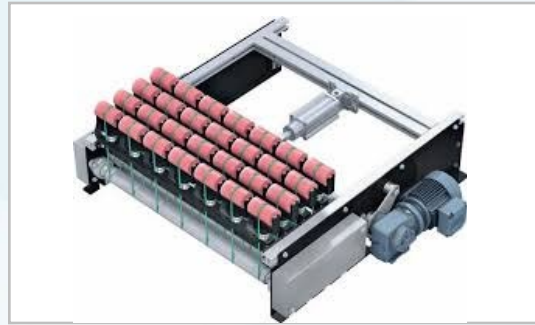

Pop-up Rollers or Roller Diverter – Rollers rise up between the chain, narrow belt, or roller conveyors to move the item off the conveyor.



Pop-up Skewed Wheel Sorter – For high-speed sorting, wheels pop up between powered rollers or belt conveyor segments to direct items onto a powered take-away line.

In-Line Diverter Types



Rake Puller – Tines pop up between conveyor rollers and pull the item across the conveyor.

Powered Wheel Diverter – Powered skate wheels rise from the conveyor bed to send objects in the desired direction.

Shoe Sorter

Also called a surfing sorter or a sliding shoe sorter, these conveyors have a surface of continuously linked slats with a shoe on one side that moves along with the slats. Independently operated, each shoe can slide across the slat as needed, coming in contact with the side of the load to move it off the main conveyor line. They are ideal for high-speed sorting.



Tilt-Tray Sorter

For the highest speed sorting, tilt tray sorters are a continuously moving train of independent trays that move in a straight line and recirculate in either a horizontal or vertical (over and under) closed loop. Controls cause the tray to tilt and discharge the load.

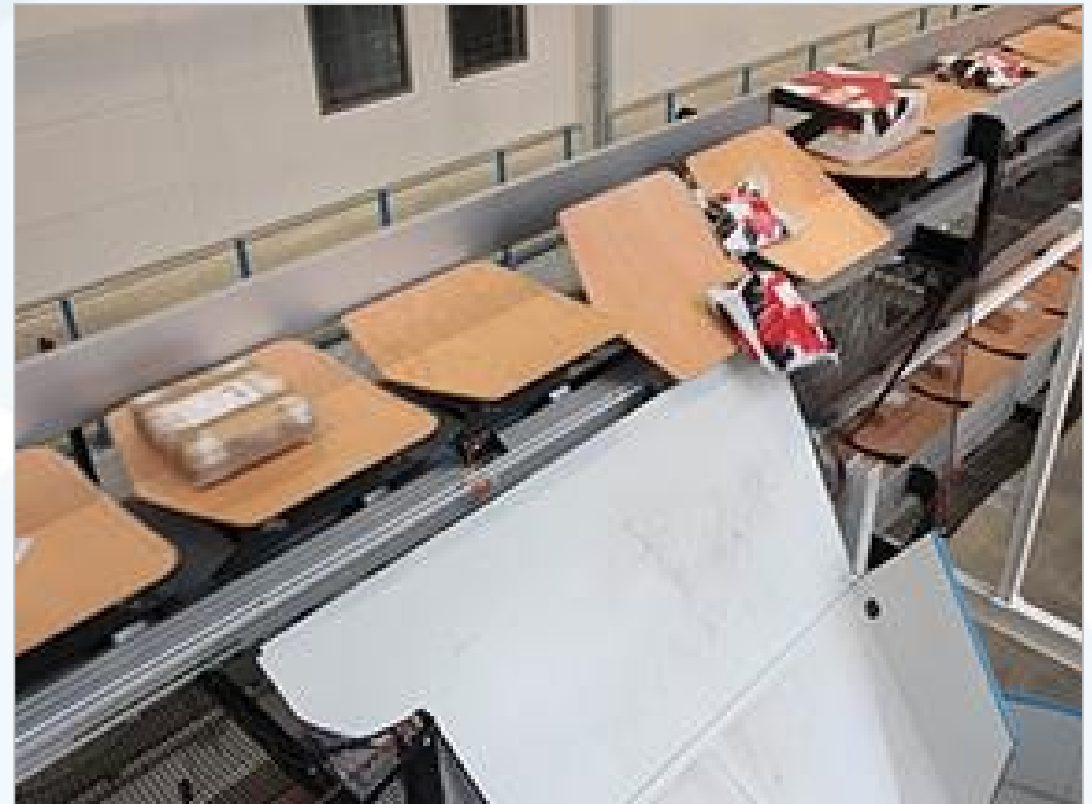

Cross Belt Sorter Conveyor

Featuring short belt, motorized conveyor sections whose orientation is perpendicular to the main route of the main conveyor travel, the load on each section is propelled off the main line by activation of the short section's motor.



Activated Roller Belt™ (ARB) Technology

Combining free-spinning angled rollers that extend above and below a modular plastic conveyor belt, products ride on the rollers' surface. Activated by a carry way surface below the belt, the rollers move products selectively in the roller orientation direction rather than the direction of belt travel.

This allows the conveyor to change the direction, alignment, location, and speed of an item independently, without rails or mechanical controls. This technology is applied to sorting, singulation, turning, switching, and aligning applications.



For More Information
Contact MHI's Conveyor & Sortation
Systems (CSS) Group
mhi.org/css

NEXT UP... MODULE 3: CONVEYOR AND SORTATION
SYSTEM MAINTENANCE AND SAFETY